

WARING COMMERCIAL®

Xtreme Blenders with 4 Reprogrammable Beverage Stations and a 64 oz. Stackable Raptor Container

MX1300XTX
MX1500XTX

comes with Sound Enclosure

Unit Information

Limited 3 Year Motor Warranty
Two Year Parts & Labor
60Hz – 13 Amps – 3.5 HP Motor
RPM's Maximum 30,000
Minimum 5,000
Height 21" – Weight 18 lbs.
One Piece Dishwasher Safe
Removable Jar Pad

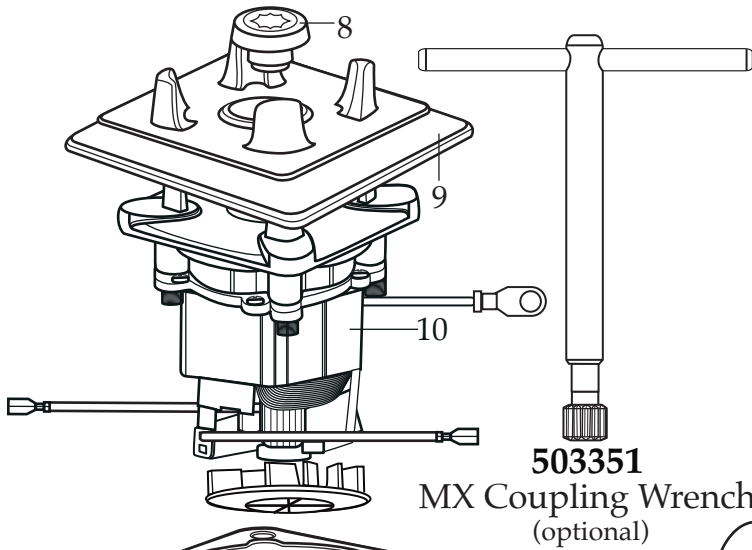

503351
MX Coupling Wrench
(optional)

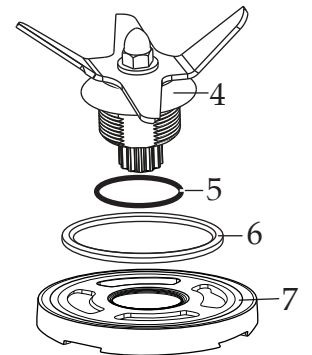
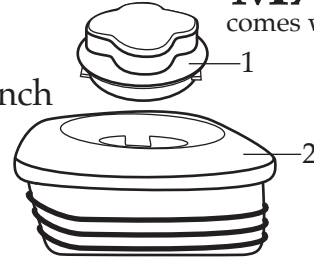

030889
Blending Assembly Kit

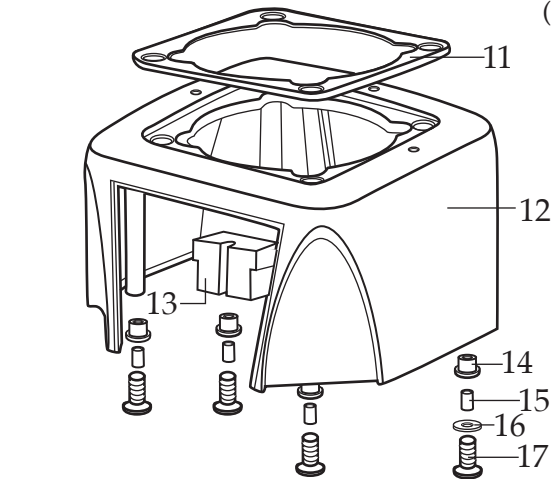

013304
NSF Seal

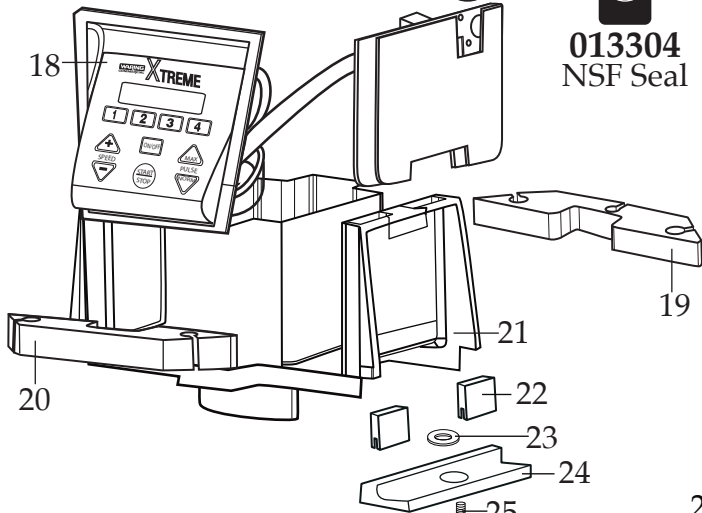
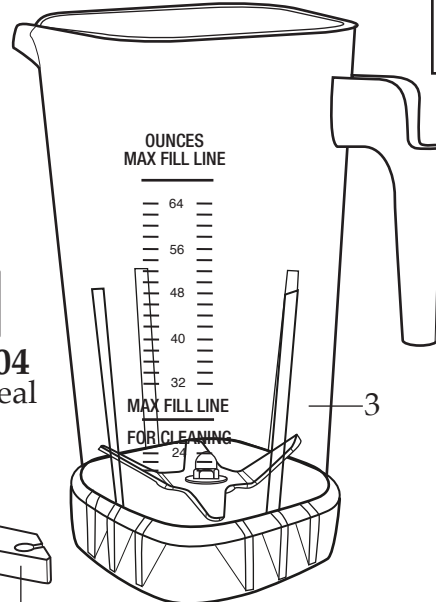

Date Code Location
YY|MM|DD
year|year|month|month|day|day

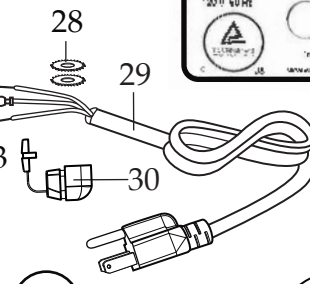
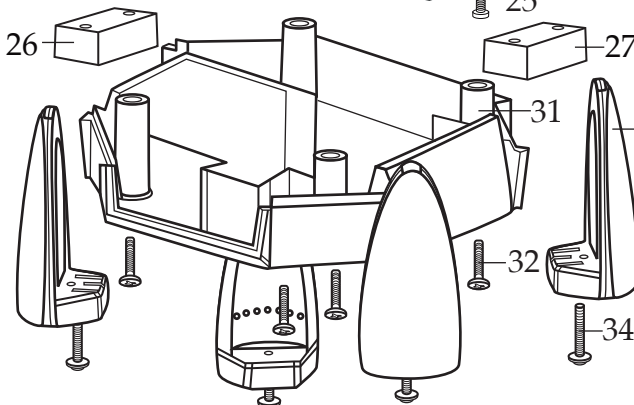

NEMA 5-15

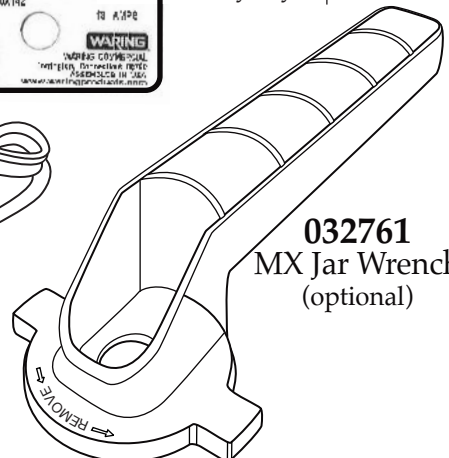

032761
MX Jar Wrench
(optional)

Catalog	Model
MX1300XTX	MX1300XT41
MX1500XTX	MX1500XT42

WARING
COMMERCIAL
314 Ella T. Grasso Ave.
Torrington, CT 06790
Tele. 1-800-269-6640
Fax 860-496-9017
www.waringcommercialproducts.com

Illustration#	Part#	Description
1	026425-E	Jar Lid Cover
2	026424-V	Vinyl Jar Lid <i>(changed after 12/3/2012)</i>
3	503326	64 oz. Stackable Raptor Container ONLY
	503398	64 oz. Stackable Raptor Container with Blending Assembly <i>(on units after 1/28/2011)</i>
	503350	64 oz. Stackable Container with Blending Assembly
4	503397	Blade Assembly <i>(changed after 1/28/2011)</i>
5	024271	Buna O Ring
6	024268	Rubber Nut Gasket
7	029631	Bearing Holder Nut
8	503601	Sq. Drive Coupling with Adapter <i>(on units after 3/29/2022)</i>
	503604	Sq. Drive Coupling with Adapter 2 Gen. <i>(changed after 5/7/2021)</i>
	028538	Drive Coupling
9	026442	Jar Pad (no sound enclosure)
10	035397	Leili Motor with Sensor <i>(on units after 9/1/2017)</i>
	028101	ECM Motor with Sensor
11	038278	Dampening Plate Gasket <i>(on units after 8/25/2022)</i>
	026437	Dampening Plate Gasket
12	028032-09	Top Housing /black
13	028541	Motor Foam (2 required)
14	026439	Dampening Plate Bushing (4 required)
15	038486	Dampening Plate Sleeve (4 required <i>on units after 8/25/2022</i>)
	026453	Dampening Plate Sleeve (4 required)
16	026459	Washer
17	028929	Sems (4 required)
18	036922	Control Panel with Interlock <i>(on units after 7/16/2019)</i> comes with key board-main board
	035610	5% Low Control Panel <i>(on units after 9/29/2017 use 036922)</i>
	029812	Soft Start Control Panel <i>(changed after 3/16/2012)</i>
19	028248	Top Housing Foam Rear Baffle
20	028249	Top Housing Foam Front Baffle
21	036814	Motor Housing 2.78" <i>(on units after 7/16/2019)</i>
	028240-67	Motor Housing <i>(on units after 9/1/2017)</i>
	028240	Motor Housing
22	034900	PCB Cushions (2 required <i>on units after 7/16/2019</i>)
23	037232	Neoprene Washer <i>(on units after 7/16/2019)</i>
24	037007	PCB Mounting Bracket <i>(on units after 7/16/2019)</i>
25	013768	Screw <i>(on units after 7/16/2019)</i>

Catalog	Model
MX1300XTXAF	MX1300XT41
MX1500XTXAF	MX1500XT42

WARING
COMMERCIAL
 314 Ella T. Grasso Ave.
 Torrington, CT 06790
 Tele. 1-800-269-6640
 Fax 860-496-9017
 www.waringcommercialproducts.com

Illustration#	Part#	Description
26	028247	Bottom Housing Foam Baffle
27	028542	Foam Baffle
28	002943	Washer (2 required)
29	026925	Cord Set
30	007556	Strain Relief
31	028241-09-X	Bottom Housing black
32	012505	Screw (4 required)
33	026430	Corner Post (4 required)
34	028928	Sems (4 required)

